

# T3350-3318

Flexible Ducting

Food & Pharma Quality Polyurethane Ducting (Smoothbore & Antistatic)

1.45mm Wall

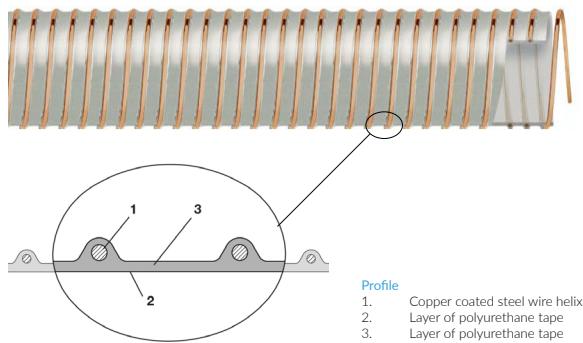

### Key Features

- Lightweight
- Resistant to abrasion and flexion
- Relatively smooth inner surface
- High flexibility and elasticity
- Good chemical resistance

### Standards & Specifications

ATEX TRBS 2153 - Antistatic to  $R < 10^9$  Ohm (Zone 20), FDA CFR 21.177.1200, FDA CFR 21.178.2010, EU Regulation 10/2011

### Description

An extremely flexible, heavy walled, FDA food quality ducting manufactured from highly abrasion resistant polyurethane (polyester) with antistatic properties.

### Applications

The smooth inner surface and abrasion resistant polyurethane material this ducting is made from make it ideal for the suction and blasting of fine particle solids, dust on filling stations and as a discharge hose in the pharmaceutical industry.

Note: Only suitable for dry products.

### Construction

#### Liner

Smooth, inner layer of FDA polyurethane (polyester)

#### Reinforcement

Copper coated, spring steel wire. A available with an inox stainless steel wire as an alternative.

#### Cover

Smooth, inner layer of FDA polyurethane (polyester)

### Temperature Range

-40°C to +90°C (+125 Intermittent)

Specification								
Size	ID (mm)	OD (mm)	Wall (mm)	Bend Radius (mm)	WP (bar)	Vacuum (bar)	Weight (kg/m)	Product Code
1"	25	33	1.45	47	4.16	0.92	0.29	T3350-3318-025-101
1 1/4"	32	41	1.45	60	3.25	0.92	0.39	T3350-3318-032-101
1 1/2"	38	47	1.45	69	3.12	0.82	0.46	T3350-3318-038-101
-	40	49	1.45	72	3.00	0.81	0.49	T3350-3318-040-101
1 3/4"	45	55	1.45	80	2.95	0.80	0.55	T3350-3318-045-101
2"	50	61	1.45	87	2.90	0.78	0.71	T3350-3318-050-101
-	55	65	1.45	95	2.75	0.76	0.77	T3350-3318-055-101
2 3/8"	60	70	1.45	102	2.55	0.73	0.84	T3350-3318-060-101
2 1/2"	65	75	1.45	112	2.40	0.66	0.91	T3350-3318-065-101
-	70	80	1.45	117	2.25	0.66	0.97	T3350-3318-070-101
3"	75	87	1.45	126	2.00	0.58	1.06	T3350-3318-075-101
3 1/8"	80	91	1.45	132	2.00	0.58	1.11	T3350-3318-080-101
3 1/2"	90	101	1.45	149	1.65	0.51	1.25	T3350-3318-090-101
4"	100	112	1.45	165	1.50	0.44	1.48	T3350-3318-100-101

Flextech Hose Solutions Ltd.

945-946 Yeovil Road  
Trading Estate, Slough  
Berkshire, SL1 4NH  
United Kingdom

Office: +44 (0) 1753 570 099

Accounts: +44 (0) 1753 378 984

Fax: +44 (0) 1753 550 011

Email: sales@flextechhose.co.uk

Website: flextechhose.co.uk

Company Registration Number: GB 7056556

VAT Number: GB 212764327

D-U-N-S: 216259232



# T3350-3318

Flexible Ducting

Food & Pharma Quality Polyurethane Ducting (Smoothbore & Antistatic)

1.45mm Wall

Specification								
Size	ID (mm)	OD (mm)	Wall (mm)	Bend Radius (mm)	WP (bar)	Vacuum (mtH2O)	Weight (kg/m)	Product Code
-	110	121	1.45	179	1.35	0.44	1.61	T3350-3318-110-101
-	115	121	1.45	179	1.35	0.44	1.61	T3350-3318-115-101
-	120	131	1.45	194	1.30	0.3	1.75	T3350-3318-120-101
5"	125	138	1.45	203	1.30	0.30	1.91	T3350-3318-125-101
-	130	141	1.45	209	1.30	0.30	1.96	T3350-3318-130-101
5 1/2"	140	151	1.45	224	1.05	0.24	2.11	T3350-3318-140-101
6"	150	163	1.45	242	1.05	0.24	2.29	T3350-3318-150-101
-	160	171	1.45	255	0.90	0.24	2.51	T3350-3318-160-101
-	170	181	1.45	270	0.90	0.18	2.67	T3350-3318-170-101
-	175	186	1.45	278	0.90	0.18	2.74	T3350-3318-175-101
7"	180	191	1.45	285	0.75	0.18	2.82	T3350-3318-180-101
8"	200	215	1.45	321	0.75	0.18	3.30	T3350-3318-200-101
-	225	237	1.45	353	0.60	0.12	3.65	T3350-3318-225-101
10"	250	263	1.45	390	0.60	0.12	3.84	T3350-3318-250-101
-	275	288	1.45	426	0.45	0.12	4.22	T3350-3318-275-101
12"	300	313	1.45	465	0.45	0.12	4.94	T3350-3318-300-101
	315	328	1.45	488	0.45	0.12	5.19	T3350-3318-315-101
	325	338	1.45	503	0.45	0.12	5.35	T3350-3318-325-101
	350	363	1.45	540	0.45	0.12	6.96	T3350-3318-350-101
	400	413	1.45	615	0.30	0.06	7.95	T3350-3318-400-101
	450	463	1.45	690	0.30	0.06	8.94	T3350-3318-450-101
	500	513	1.45	765	0.30	0.06	9.93	T3350-3318-500-101